

## SMALL PARCEL & BAGGAGE X-RAY IMAGING SYSTEM

# XRC 75-55



**XRC 75-55** x-ray baggage scanner enables operators usage with the help of various image processing functions, hazard alarm, advanced computer technology and the best in class software. It makes it extraordinarily easy to detect threats such as cutting tools, explosive narcotics and reduces the rate of error.

Thanks to its multi-diode structure and quality in imaging of scanned objects image is colored based on density and shows organic, inorganic and mixed materials in different tones. It is designed with the latest technology system to scan small handbags, packages parcels and cabin baggage in detail. Courts, police departments, offices, shopping malls, prisons and hotels are its main areas of application.

# TECHNICAL DATA XRC 75-55

## PHYSICAL PROPERTIES

Tunnel Size	: 755 mm x 555 mm
(W x H)	: 29,72 in x 21,85 in
Dimensions	: 2180 mm x 1480 mm x 1030 mm
(L x H x W)	: 85,83 in x 58,27 in x 40,55 in
Approx. Weight Unpacked	: ~635 kg (1400 lbs.)
Conveyor Height	: 810mm (31,89 in)
Conveyor Load Capacity	: 165 kg (364 lbs.) Evenly Distributed
System Power	: 110/220V AC ± 10% 50/60 Hz, 5amp max.
Conveyor Speed	: 0,20 m/sec. Forward or Reverse

## X-RAY GENERATOR & IMAGE PERFORMANCE

Steel Penetration <sup>1</sup>	: 37 mm guaranteed; 39 mm typical
Wire Resolution <sup>1</sup>	: 38 AWG guaranteed; 40 AWG typical
Anode Voltage	: 170kV, operating at 160kV
Tube Current	: 1,0 mA
Beam Direction	: Vertically upward
Article Separation	: Low Z, Medium Z, High Z to 0,5 Z Accuracy
Cooling	: Oil and forced air cooling

## COMPUTER SPECIFICATIONS

Processor	: Intel® Core™ i5 (or superior)
Monitor	: 21,5" Flat (or superior)
Memory	: 4 GB RAM (or superior)
Video Card	: 2 GB (or superior)
Hard Drive	: 1 TB (or superior)
USB Port	: 6 port (or superior)
Operating System	: Linux

## OPERATING ENVIRONMENT

Storage / Operating Temperature	: -20°C to 50°C / 0°C to 40°C (-4°F to 122°F / 32°F to 104°F)
Relative Humidity	: 10% to 90% non-condensing

## HEALTH AND SAFETY

All X-Ray Center Ltd products meet all applicable international health and safety regulations.

US FDA Federal Standard 21CFR 1020.40

Health and Safety at Work Act 1974-compliant 6 : Available

Film Safety : ISO 1600 / 33 DIN

CE Compliance : Certified

FCC & IEC Compatibility : Available

IP 20 Safety : Certified

Maximum level of radiation the exterior panels come in contact with is 0.1 mR/hour

## OPTIONAL FEATURES

- Barcode Reader System
- External Camera Archiving
- Remote Viewing Station
- Recheck Station
- Network Supervisory System (NSS)
- Remote Access Connection
- Smart Card Login

## OPTIONAL ACCESSORIES

- External UPS (For system)
- Operator Console (Open-Closed/Adjustable/I-stand)
- 21,5" - 27" Flat Monitor
- Input / Output Rollers
- Test Kit (STP/ASTM)
- Protective Cover
- Search Table
- Tray Return System (Motorized/Gravity)
- Inclined Conveyor
- Ultrasonic Rat Repellent
- Radiation Meter

## STANDARD IMAGE PROCESSING FEATURES

- Perfect View (Detail Enhancement) (PV)
- Edge Enhancement (EE)
- Pseudo Color (PS)
- Organic Materials (OM)
- Inorganic Materials (IM)
- Black & White (B/W)
- Inverse Colors (IN)
- High Penetration (HP)
- Variable Edge Enhancement (+E -E)
- Variable Density (+D -D)
- Variable Gamma (+G -G)
- Variable Color Separation (+C -C)
- Zoom (64x)
- Sniper Zoom
- Recall Previous Images
- Manual/Automatic Archive
- Annotated Archive
- Multi Energy Viewer (4 - 6 Color)
- Atomic Number Display (Z Value)

## STANDARD FEATURES

- Programmable Function Keys
- Parcel Counter
- Date and Time Display
- Virtual Threat Image Projection (TIP)
- Organic/Inorganic Threat Alarm
- Operator Training Program (OTP)
- UPS (For Computer Supply)
- Multi Languages
- Self Diagnosis
- Generator Timer
- Automatic Stop Conveyor

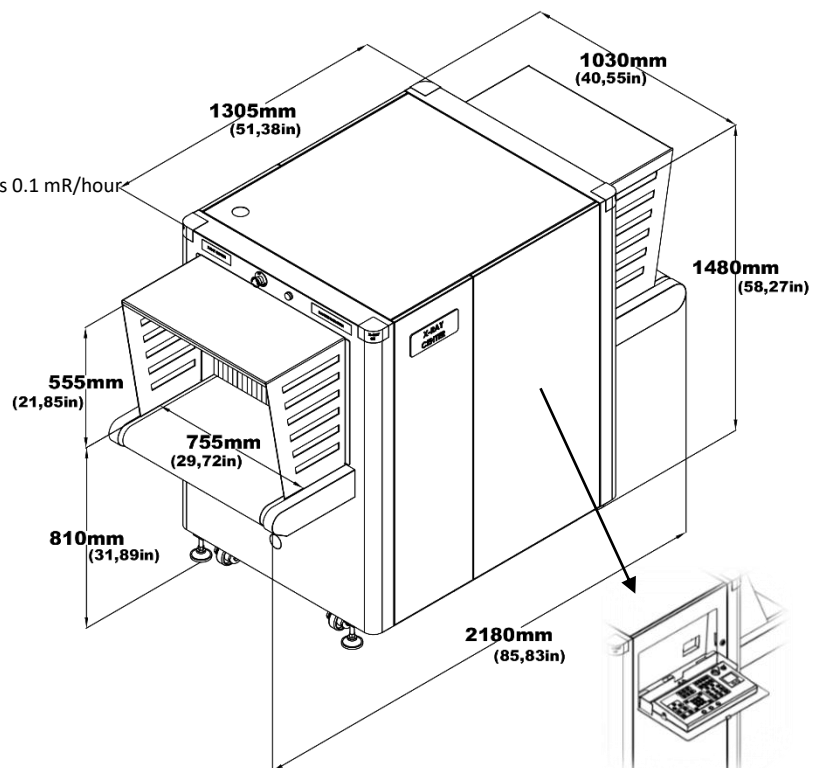

The keyboard can be produced optionally as integrated into the device.

<sup>1</sup>As tested on X-Ray Center Ltd. test piece. Conveyor speed is 0.20 m/sec.

Products certified as TSA, ECAC and so on are available as an option. Please inquire from your dealer.

Due to continuous product development, X-Ray Center reserves the right to change specifications without notice.

